

Non-Porous Conveyor Line Printer

U.S. PATENT NO. 5,109,769 E.P. PATENT NO. 0508971

Universal Non-Porous Conveyor Line Printers provide the ultimate in low maintenance printing on all types of non-porous materials. Unmatched in quality and performance, these printers have completely eliminated the problems associated with the use of fast drying inks.

The revolutionary design of our patented Non-Porous Inking System prevents solvent evaporation from the ink roll and enables the use of inks that dry as fast as 2 seconds at 75 degree F. ambient temperatures.



A patented disposable Reservoir Ink Cartridge is used to recharge the ink roll automatically on demand during the printing operation. These coders are compatible with a variety of alcohol base inks in both dye and pigmented formulations, including Mil Spec Stencil Inks.

The Non-Porous Conveyor Line Printer has an 18" circumference print drum. Models are available with 1" and 2" print widths in both indexing & non-indexing styles. Top Mount configurations are used for printing on horizontal surfaces such as continuous web materials and side mount configurations are used primarily for printing on the sides of cartons or other vertical surfaces. These coders are ideal for printing on plastic, metal, rubber, glass, waxed or varnished cartons.

Features include precision machined aircraft aluminum housings, stainless steel columns & shafts and sealed ball bearings in both the print drum and anilox roll. Mounting brackets and RIBtype® print drums are standard equipment.

CLP-100 Series

Print Area: 1" x 18" (25mm x 457mm)
 Net Weight: 10 LBS. 12 OZ. (4.88 KG)
 Dimension: "A" = 3.900" / "B" = 1.555"
 Dimension: "C" = 1.125" / "D" = 4.927"

SPECIFICATIONS

CLP-200 Series

Print Area: 2" x 18" (50mm x 457mm)
 Net Weight: 11 LBS. 5 OZ. (5.13 KG)
 Dimension: "A" = 4.824" / "B" = 2.480"
 Dimension: "C" = 2.050" / "D" = 5.802"

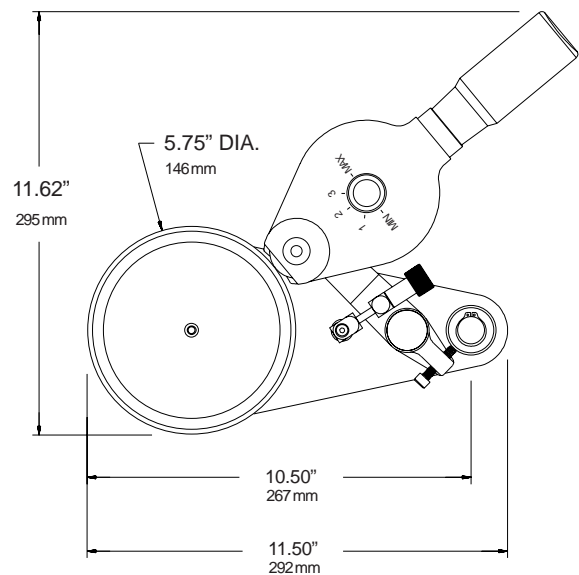
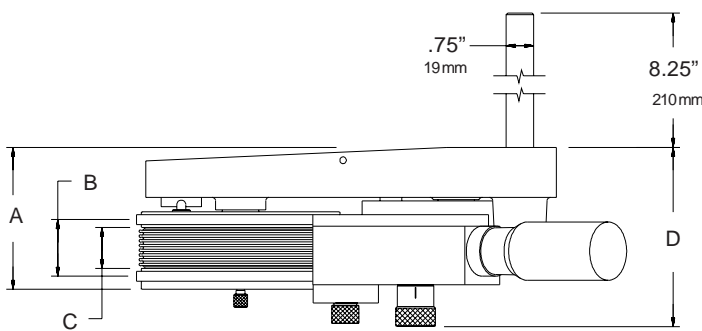

Manufactured By

Universal Stenciling & Marking Systems, Inc.

P.O. Box 871 • St. Petersburg, FL 33731 • U.S.A.

Ph: (727) 894-3027 • E-Mail: sales@universal-marking.com • Website: www.universal-marking.com